

**TENNESSEE  
ROYAL RANGERS  
POW WOW 2024**

**June 10 – 15, 2024**



**Matthew 16:18**

Updated 2/12/24



# Table of Contents

<b>CAMP STAFF</b> .....	4
<b>RANGER ADVENTURE WEEK</b> .....	5
<b>JUNIOR LEADERSHIP DEVELOPMENT ACADEMY</b> .....	5
<b>FRONTIERSMAN CAMPING FELLOWSHIP</b> .....	5
<b>POW WOW</b> .....	5
<b>CAMP SCHEDULE</b> .....	6
<b>THEME</b> .....	7
<b>SCRIPTURE</b> .....	7
<b>SPEAKER</b> .....	7
<b>SPECIAL MUSIC</b> .....	7
<b>DATE</b> .....	7
<b>LOCATION</b> .....	7
<b>COST</b> .....	7
<b>MISCELLANEOUS ANNOUNCEMENTS</b> .....	8
<b>CHECK-IN</b> .....	8
<b>SENIOR GUIDES/COMMANDERS MEETING</b> .....	8
<b>MORNING FORMATION</b> .....	8
<b>SPECIAL PRESENTATIONS</b> .....	8
<b>HIKE AND COUNCIL FIRE</b> .....	8
<b>RAW PATHFINDER TEAM</b> .....	8
<b>WHAT TO BRING</b> .....	9
<b>REGISTRATION</b> .....	10
<b>REGISTRATION DEADLINE</b> .....	10
<b>STAFF REGISTRATION</b> .....	10
<b>OPTIONAL ITEMS WITH REGISTRATION</b> .....	11
<b>MISSIONS AND RANGER ADVENTURE WEEK</b> .....	12
<b>MASTER’S TOOLBOX</b> .....	12
<b>SILENT AUCTION</b> .....	12
<b>CAMP STORE</b> .....	12
<b>MISSION TRIP SCHOLARSHIP</b> .....	12
<b>TENNESSEE JUNIOR LEADERSHIP CAMP</b> .....	13

<b>FCF VILLAGE .....</b>	<b>16</b>
<b>CAMP SAFETY .....</b>	<b>17</b>
<b>CAMP RULES .....</b>	<b>18</b>
<b>COMPETITIONS .....</b>	<b>19</b>
<b>BEST OUTPOST STANDARD (FIRST &amp; SECOND PLACE TROPHIES).....</b>	<b>19</b>
<b>BEST GATEWAY (FIRST &amp; SECOND PLACE TROPHIES) .....</b>	<b>19</b>
<b>BEST CAMPSITE (FIRST &amp; SECOND PLACE TROPHIES) .....</b>	<b>19</b>
<b>SOCCER .....</b>	<b>19</b>
<b>TUG OF WAR .....</b>	<b>19</b>
<b>.22 RIFLE, SHOTGUN, BB GUN, AND ARCHERY .....</b>	<b>19</b>
<b>TOP SHOT .....</b>	<b>19</b>
<b>WATERMELON EATING.....</b>	<b>19</b>
<b>CARDBOARD REGATTA.....</b>	<b>20</b>
<b>JUNIOR BIBLE QUIZ FACT-PAK .....</b>	<b>24</b>
<b>LINKS FOR FORMS .....</b>	<b>27</b>
<b>OUTPOST REGISTRATION FORM .....</b>	<b>27</b>
<a href="https://www.cognitofrms.com/TNRoyalRangers/_2024TNPOWWOWREGISTRATIONFORMOUTPOST">https://www.cognitofrms.com/TNRoyalRangers/_2024TNPOWWOWREGISTRATIONFORMOUTPOST</a> .....	<b>27</b>
<b>BOYS REGISTRATION FORM .....</b>	<b>27</b>
<a href="https://www.cognitofrms.com/TNRoyalRangers/_2024TNPOWWOWREGISTRATIONFORMBOYS">https://www.cognitofrms.com/TNRoyalRangers/_2024TNPOWWOWREGISTRATIONFORMBOYS</a>	<b>27</b>
<b>ADULT REGISTRATION FORM.....</b>	<b>27</b>
<a href="https://www.cognitofrms.com/TNRoyalRangers/_2024TNPOWWOWREGISTRATIONFORMADULTS27">https://www.cognitofrms.com/TNRoyalRangers/_2024TNPOWWOWREGISTRATIONFORMADULTS27</a>	
<b>JLDA REGISTRATION FORM .....</b>	<b>27</b>
<a href="https://www.cognitofrms.com/TNRoyalRangers/_2024TNJLDAREGISTRATIONFORMBOYS">https://www.cognitofrms.com/TNRoyalRangers/_2024TNJLDAREGISTRATIONFORMBOYS</a> .....	<b>27</b>
<b>RANGER RUN AND NATURE WALK 5K.....</b>	<b>27</b>
<b>PAINTBALL LIABILITY WAIVER FORM .....</b>	<b>27</b>
<b>COMPETITION ENTRY FORM .....</b>	<b>27</b>
<a href="https://www.cognitofrms.com/TNRoyalRangers/_2024TNPOWWOWCOMPETITIONSENTRYFORM27">https://www.cognitofrms.com/TNRoyalRangers/_2024TNPOWWOWCOMPETITIONSENTRYFORM27</a>	
<b>POWWOW PATHFINDER APPLICATION FORM .....</b>	<b>27</b>
<b>PAYMENT INFORMATION.....</b>	<b>27</b>

## CAMP STAFF

<b>Camp Commander</b> .....	Ron Bush
Assistant Camp Commander .....	Dave Andrews
<b>JLDA Coordinator</b> .....	Dave Meier
Assistant JLDA Coordinator .....	Earl Keith
<b>FCF Camp Coordinator</b> .....	Ron "Spirit Bear" Parker
FCF Camp Assistant .....	Paul "Grey Beard" Gallina
<b>Pow Wow Coordinator</b> .....	Tim Hathcock
Camp Assistant .....	Scott Tollett
Junior Camp Assistant .....	Trevor Scott
Missions Coordinator .....	Ron Harrison
Morning Formations .....	Wild Bill Yancey/Nate Harris
Honor Guard .....	Trevor Scott
Chief Judge.....	Scott Potter
Games Coordinator.....	
Sound and Lighting .....	
Trophies/Awards.....	Dave Meier
Concessions .....	Mike Childers
Videography / Photography .....	
On-Site Logistics.....	
Volunteer Coordinator.....	Steve Iles
Cleaning Services & Teardown (4) .....	
<b>Registration</b> (Pre-Camp, Mail In) .....	Steve Iles
Check-In (at camp) .....	Steve Iles
<b>Safety Coordinator</b> .....	Dave Meier
Security.....	Josh Guin
First Aid Coordinator.....	Keith Porter
Parking .....	

**RANGER ADVENTURE WEEK will feature three simultaneous events running throughout the entire week of Monday, June 10 - Saturday, June 15.**

JUNIOR LEADERSHIP DEVELOPMENT ACADEMY is a district leadership training event for boys in Grades 5 and up. Boys attending this event will learn leadership skills that can benefit them in all areas of life. See pages 13-15 or contact [dave.meier@att.net](mailto:dave.meier@att.net) for more information.

FRONTIERSMAN CAMPING FELLOWSHIP is a special program of Royal Rangers that provides boys and men with additional opportunities to develop specialized outdoor skills based on the lore and traditions of the early American frontiersman. The activities and feel of a "Trace" camp will be featured in the afternoon hours to allow boys to see the camp in action. A special evening service for the FCF membership will be held one night. Contact [crazywolfga@aol.com](mailto:crazywolfga@aol.com) or [ron@doorhangersinc.com](mailto:ron@doorhangersinc.com) for more information about FCF.

**\*\*\*\*\* *Boys attending JLDA will still have ample time and opportunities to participate in the games, competitions, and other Pow Wow events.* \*\*\*\*\***

POW WOW is for boys entering Grades 3-12. Exciting games and competitions, as well as nightly worship services, will provide plenty of fun for active boys. Please read this entire handbook to see what is offered at our greatest annual event. After reading this book, feel free to email questions to Tim Hathcock at [timothy.hathcock@gmail.com](mailto:timothy.hathcock@gmail.com).

This camp is limited to boys in the Discovery, Adventure, and Expedition Ranger groups (entering Grades 3 - 12). This camp is not designed for, nor intended for, Ranger Kids (2<sup>nd</sup> grade and younger). DO NOT bring younger boys, even if escorted by a parent!

Any church that has not yet chartered is invited to bring your boys to Pow Wow. [Click HERE for more information about chartering.](#)

Familiarize yourself and your boys with the information in this handbook as you prepare for the many activities of Ranger Adventure Week. Check the website (<http://tnrangers.org>) regularly for possible updated information. Pray for this event to be a positive, life-changing experience for all participants. Submit your registrations early and begin planning now to receive a blessing from God and to be a blessing to other men and boys.

# CAMP SCHEDULE

## JLDA Typ. Day

7:00 AM	Wake up
7:15 AM	Personal Devotion #3 (Student Notebook)
7:30 AM	Breakfast
8:00 AM	Morning Formation
	Dedicated JLDA Activities
12:00 PM	Lunch
5:00 PM	Dinner
8:30 PM	Evening Service
10:00 PM	Lights Out

## F.C.F. Typ. Day

7:00 AM	Wake up
7:15 AM	Personal Devotions
7:30 AM	Breakfast
8:00 AM	Morning Formation
12:00 PM	Lunch @ Village
	Dedicated FCF Activities
3:00 PM	
5:00 PM	Dinner
8:30 PM	Evening Service
10:00 PM	Lights Out

## Pow Wow Typ. Day

7:00 AM	Wake up
7:15 AM	Personal Devotions
7:30 AM	Breakfast
8:00 AM	Morning Formation
12:00 PM	Lunch
3:00 PM	Dedicated Pow Wow Activities
5:00 PM	Dinner
8:30 PM	Evening Service
11:00 AM	Lights Out

THEME — **ROCKY TOP**

SCRIPTURE — **“UPON THIS ROCK”- Matthew 16:18**

SPEAKER — **Terry Bailey** - TN District Superintendent

**Tim VanDouser** - Pastor, Whitefield Assembly of God

**Victor Gomez** - Pastor, Una Esperanza Viva

SPECIAL MUSIC — **TN RR Boys**

DATE — **June 10 – 15, 2024**

Check-in 9:00-12:00 Monday morning for all camps

Leaders Meeting 2:00-3:00 Monday afternoon for all OP Senior Guides

One Commander from each OP may also attend if he wishes.

JLDA Recognitions Thursday night

Pow Wow Award Ceremony Saturday morning (You may leave after the ceremony.)

Clear campground by 1:00 on Saturday.

LOCATION — Jackson Conference Center (Camp Jackson), 2601 Greer Rd., Goodlettsville, TN 37072

[CLICK HERE FOR MAP](#)

COST - Friends of Rangers is subsidizing the cost of Ranger Adventure Week to make the experience more affordable for everyone. The minimal charge of \$100 to \$160 (See chart below.) per person covers the registration fee for an entire week of camp.

Time of Registration	Chartered Outpost	Non-Chartered Outpost
Early: By April 10	\$100	\$120
Regular: By May 15	\$120	\$140
Late: After May 15	\$140	\$160

The full registration price is required from EVERY *boy, commander, frontiersman, staff member, and volunteer worker* (both male and female), regardless of housing or meal plan.

## MISCELLANEOUS ANNOUNCEMENTS

**CHECK-IN** Monday at 9:00 a.m. for all camps.

All funds owed after the original \$50 deposit are due upon check-in at camp. No exceptions will be made.

Upon check-in you will receive shirts and hats. Wristbands signifying paintball permission slips will be distributed upon check-in. No other wristbands will be needed. You will not receive your patches until the end of the camp. If you must leave early, please make that known at check-in so provision can be made to mail the patches to your home church.

**SENIOR GUIDES/COMMANDERS MEETING** — The final schedule and other updates will be covered at the Outpost Senior Guide Meeting on Monday at 2:00 (CDT). *It is **especially important** that ONE Senior Guide from each Outpost attend this meeting to get all the needed information for Pow Wow.* One commander from each Outpost may also attend if he wishes.

We will have a “Points of Interest” printout to give to the boys at this meeting.

### **OUPPOST NUMBER MUST BE POSTED AT YOUR CAMPSITE OR CABIN**

For security/safety reasons, every outpost is required to post the number of their outpost at the entry to their campsite or cabin. This is typically done by creating a gateway depicting the camp’s theme. We encourage all outposts to participate in the Gateway competition, but regardless of participation, posting the outpost number is required.

### **MORNING FORMATION**

There will be a morning formation for all outposts at the camp, complete with presentation of colors and reporting of the sections, every morning Tuesday through Saturday. All campers should wear the Pow Wow t-shirt and cap to formation on Tuesday morning for the group photo. District staff will wear district Pow Wow t-shirts and FCF members are encouraged to wear their FCF outfits on Tuesday morning for the photo. Also, bring chairs or blankets for your comfort after opening ceremonies are completed.

### **SPECIAL PRESENTATIONS**

If you or your outpost wants to recognize someone who has had a special impact in your organization or life, you may give them a “Special Presentation” at the Friday morning formation. Please be sure your Special Presentation is indeed special and worthy of your efforts. All these presentations must be pre-approved by the Morning Formation Coordinator prior to the presentation.

### **HIKE AND COUNCIL FIRE**

We will have a hike Wednesday night to a Council Fire where our service will be held. *Bring your own camp chairs.*

### **RAW PATHFINDER TEAM**

Men and boys ages 14+ are invited to join the RAW Pathfinder team to work at camp before, during, and after Pow Wow. You do not have to be active in Royal Rangers to join the Pathfinder team. Team members will gather at camp before noon on Sunday for lunch, team orientation, and camp setup. The team will assist in running games and events, cleaning camp facilities, and miscellaneous other tasks. Team members will be given time to participate in Pow Wow events, but their primary duty is to help the camp staff. Applicants to the RAW Pathfinder team must submit the RAW Pathfinder Application Form in addition to submitting the regular Ranger Adventure Week Registration Form. A limited number of applicants will be accepted. The registration fee is the same as the regular camp registration fee and has the same deadlines for submission.



## WHAT TO BRING

### *For Outposts:*

- *Individual Registrations for ALL Participants*
- *Balance of Money Due*
- *Competition Entry Forms*
- *First Aid Kit – The first-aid merit gives a list of what should be in your kit.*
- *Master’s Toolbox Offering*
- *Mission Trip Scholarship Essays, if applicable*

### *For Individuals:*

- **Camp Chairs** – Each camper is encouraged to bring a chair.
- **Personal Non-Disposable Water Bottle** – Each camper will need a personal water bottle to keep with him. We will have water stations set up around the camp but may **not** always have cups available.
- **Trade Items** - Traders Row in the FCF Village will be open at various times for active trading. Bring trinkets and treasures you’ll want to trade.
- **Silent Auction Items** - Outposts are encouraged to bring items for the silent auction to raise money for missions.
- **Spending Money** – Bring extra money for concessions, camp store items, and silent auction items.

# REGISTRATION

## REGISTRATION DEADLINE

EARLY DISCOUNT REGISTRATION DEADLINE: April 10

REGISTRATION DEADLINE: May 15

LATE FEE ADDED: after May 15

Registrations must be RECEIVED BY the date shown or they will incur a late fee. Registrations prior to May 15 will receive shirts, hats, and patches. There will be a few extra shirts and hats that will be sold on-site but will not be included in registrations after May 15.

**All** adults (visitors, parents, commanders, and volunteers) 18 years of age and older are required to have their pastor's signature on the registration form. This signature approves the applicant for working with children and assumes liability for having a current national criminal background check on file at the local church.

**Adult leaders** should submit their registrations and deposits by the deadline shown on the form. Workers coming early to help set up camp need to let us know the DAY AND TIME you will arrive so we can plan meals for you.

Do not bring boys early unless cleared by Pow Wow Coordinator.

**The full registration price is required from EVERY commander, frontiersman, staff member, and volunteer worker (both male and female) regardless of housing or meal plan.**

A **non-refundable \$50 deposit** must be paid with each registration. The remaining balance, if not paid before camp week, is due upon your arrival at camp. Refunds for non-attendance will not be made for any reason. The advance purchases for food and supplies will have already been made based on pre-registration numbers. We appreciate your understanding in this matter.

## STAFF REGISTRATION

We appreciate your dedication to helping with the camp, but **YOU MUST REGISTER BEFORE APRIL 10**. Late fees also apply to you. We need to know when you will arrive on-site so we will be able to coordinate meals and work schedules.

## OPTIONAL ITEMS WITH REGISTRATION

- CAMPING – Outposts are encouraged to camp. Women wishing to camp must let us know as early as possible so we can prepare a place for them.
- CABINS – We provide cabins for an additional **\$50 per person** fee. Special requests will be handled on a first-come, first-served basis for complete registrations only.
- MEALS – Meals will be provided by the kitchen staff at no extra charge ***beginning with Monday lunch***. Outposts are welcome to cook at their campsite. A concession stand will be open with various sodas, chips, popcorn, candy, etc., during camp.
- ADDITIONAL HATS, SHIRTS, PATCHES – Extra hats, shirts, and patches are excellent gifts for your pastor or boys in your outpost who cannot attend. These may be ordered on your form. Be sure to indicate the sizes required for these extras.
- GROUP PHOTOS – Photos will be available for pre-purchase so all who are interested can get a copy ordered.
- PRAYER COINS - *We will have a Pow Wow PRAYER COIN for the first 100 people to register for Pow Wow and for volunteers who help us for two or more time slots.* We have a limited number of coins, so they will go to the first volunteers. Please send your preferred places to volunteer to Tim Hathcock at [timothy.hathcock@gmail.com](mailto:timothy.hathcock@gmail.com). We need help with games, security, general moving things around, kitchen, hauling trash once a day, concession stand, archery, 22 rifle, shotgun, BB guns, judging, paintball, referee games, watch swimming pool, watch finish lines, 5K Run/Walk, etc. We also need volunteers to stay on Saturday afternoon to help store equipment and clean the camp.
- 5K RANGER RUN / WALK – We will have a 5K race to raise BGMC funds that will help pay for a boy to go on a mission trip within the next 12 to 24 months. The cost for entry will be \$20 each and must be pre-registered. Each runner/walker will receive a t-shirt. Serious runners will be timed to the second as near as possible. See registration form.

# MISSIONS AND RANGER ADVENTURE WEEK

## MASTER'S TOOLBOX

Royal Rangers has partnered with BGMC through Master's Toolbox to raise funds for specific missions projects. This year we are partnering to build churches in countries that need a church building. We are targeting to raise funds to enable the boys of Tennessee to build a church with our Ranger Adventure Week missions offering.

Each outpost is challenged to raise funds and bring them to camp. The church shown here can be built for \$12,000 and we are setting a goal to raise this amount. Please help your outposts collect their BGMC funds and bring them with you to camp. We will collect all the money raised and see if we can go over the top in meeting the need to build more churches around the world!



BGMC has created a special offering box for Royal Rangers to use to collect money for the "Masters Toolbox" program. These FREE boxes can be ordered from My Healthy Church at 1-855-642-2011.

Ask for item number 742-893.

## SILENT AUCTION

We will have items at Pow Wow to be auctioned off by silent auction. These will be donated items and 100% of the money raised will go to missions. Outposts are encouraged to bring items for the missions' auction.

## CAMP STORE

We will also have lots of interesting items for sale in our camp store to raise money for missions. There will be t-shirts, leather goods, skins, and so much more. You'll definitely want to bring some extra spending money!

## MISSION TRIP SCHOLARSHIP

Friends of Rangers will award a scholarship up to \$2,000 to send a Royal Ranger boy on a mission trip. TN Royal Ranger Alumni will also award a scholarship to send a Royal Ranger boy on a mission trip. To nominate a boy for one of these scholarships, a commander, a pastor, or the boy himself may submit an essay of less than 200 words stating why the applicant is deserving of the scholarship. These essays are due no later than noon on Friday. The essays will be judged during camp and two winners will be determined for deserving young men to receive a Mission Scholarship. These funds may be used toward attending a Tennessee sponsored Mission trip.

Let's encourage these young men to share what is on their hearts. It's not too early to start writing!

# **JUNIOR LEADERSHIP DEVELOPMENT ACADEMY**

## **A Great Training Camp with Lots of Fun**

### **What is JLDA – And how can it benefit me and my outpost?**

JLDA serves to help all outposts by providing leadership instruction and development for the boys. After the camp your boys will be able to help lead the parts of a meeting and know more of what's expected from them when they start in leadership roles.

They will be challenged and encouraged to work with a patrol to demonstrate how their group can achieve excellence and learn to work together. This helps your outpost when they return and model that behavior for your boys.

Each boy will better know his strengths and will be challenged to use them in serving others. Please provide opportunities for them to grow when they return home to your outpost.

#### **Q & A:**

- Do only the few need to sign up? NO – This training will benefit EVERY boy in your outpost.
- Will my boys miss out on Pow Wow activities? No! Only having classes and activities in the morning allows all activities to be available for everyone – Even Traders Row and shooting sports!
- Is there an additional cost? No! There are no extra fees so that it can be open to every boy.
- What if my boys did not participate before? The classes are designed to be age based, so boys get to fellowship with those of the same age –
- What is required for the Trail of the Saber? For those that want to follow the trail of the Saber, you will need to start with JTC (Junior Training Camp) and be no older than 15. A partial listing of requirements is below.

## JLDA – @ Tennessee’s 2024 Pow Wow Week

**Come be a part of it!**

**Ranger Training Camp – Grades 5-6**

**Junior Training Camp – Grade 7 and above**

**Advanced Junior Training Camp – Grade 8 (and completed JTC)**

**All Outpost Leaders - challenge your boys to attend a camp that will benefit them as well as your outpost.**



**Location:** Jackson Conference Center, Goodlettsville, TN

**Cost:** included in Ranger Adventure Week registration; no additional fees required (Refer to cost schedule in Handbook.)

**Registration:** Forms at <https://tnrangers.org/tn-pow-wow/>

**More info:** [dave.meier@att.net](mailto:dave.meier@att.net)

# 2024 TN Junior Leadership Development Academy



**Ranger Training Camp (RTC)** is a district leadership-training event for boys from the 5th grade and not yet in the 7<sup>th</sup> grade. RTC prepares boys to serve as junior leaders in a boy-led, adult-facilitated outpost.

***RTC will help boys discover answers to these questions:***

What is my role in my patrol and group?

What are some of my God-given (natural) talents and strengths?

How do I add value to my patrol and group?

What responsibilities can I undertake to help my patrol/group?



**Junior Training Camp (JTC)** is a district training event for boys in the 7th grade or above. JTC focuses on leadership development in the local patrol and group. JTC is a required event for the Trail of the Saber Award

***JTC will help boys discover answers to these questions:***

What are my God-given talents and strengths and how am I developing them?

Do I have what it takes to be a godly man?

What is God's plan for my life?



**Advanced Junior Training Camp (AJTC)** is a district event for boys in the 8th grade or above who have already completed JTC. AJTC focuses on leadership development by serving in group and church leadership roles for young men. AJTC is a required event for the Trail of the Saber Award.

***AJTC will help boys discover answers to these questions:***

Am I following God's plan for my life today?

How am I developing my godly character?

How am I helping (serving) others?



## TRAIL OF THE SABER – CAMP REQUIREMENTS

The following requirements must be met before reaching 18 years of age in order to qualify for the Trail of the Saber award. (other qualifications are in the Leader Manual)

- Be at least 14 years of age and a graduate of the 9th grade.
- Earn (8) leadership merits of any color (red, gold, or sky blue).
- Complete Junior Training Camp (JTC) and Advanced Junior Training Camp (AJTC).
- Complete two Action Camps or Junior Academy (JA) and one Action Camp.

# FCF VILLAGE

Frontiersmen, please honor the intent of the village by covering all appearances of 21st century items.

Craft demonstrations and FCF-style competitions are planned for the FCF Village. Knife throwing and hawk throwing competitions will be held in the village. Also, there will be Flint and Steel fire starting competition. Awards will be provided for first place and runner up for each event.

**Traders Row** will be open for active trading at various times during the week. A schedule will be distributed at camp. Come prepared with some items you'll want to trade.

The **FCF Communion Service** will be at 9:00 p.m. Friday evening. Please allow your FCF boys to participate in this communion fellowship time with their FCF friends and with our Lord.

## **Guidelines for Camping in the Village:**

- Boys are permitted to live in the FCF Village under strict guidelines:
  - Must be at the Buckskin level
  - Must stay in a primitive shelter
  - Must work in an FCF trade or assist an old-timer in his trade
  - Must be approved by FCF President Greg Atwell-<mailto:crazywolfga@aol.com>
  - Must be in FCF outfit when in the village

The old-timers living in the village have a responsibility to mentor these young bucks by setting the example of an "authentic" village. This includes active skill demonstrations, storytelling, period items, outfits, etc.



# CAMP SAFETY

## MOTORIZED VEHICLES AND PARKING

- Motorized vehicles will be restricted to needs-based operation only (for example, health reasons or moving supplies for an event, etc.) in designated areas and must be cleared with the Safety Coordinator ahead of time. All motorized vehicles must be approved by the Pow Wow Coordinator.
- Motorized vehicles must be operated with caution, or the Pow Wow Coordinator may revoke permission for them. Caution must be exercised at all times for pedestrian traffic in all areas of the camp. Trucks, vans, cars, and buses will be permitted only to load or unload gear and must then be moved to the designated parking location and left there.
- Auxiliary motor vehicular traffic (ATV's, golf carts, etc.) will be limited to specific persons with direct permission from the Safety Coordinator. These vehicles should NEVER be run at top speed!
- Vehicles must remain parked in designated locations only and cannot be left in the camping areas or throughout the property. Unloading will be permitted, but the vehicles must be moved right after unloading so other outposts will have access. Working vehicles must observe pedestrian rights of way.

**HORSES** – Horses may be present in camp. Always let the rider know you wish to approach before getting within three feet of a horse. Never run when approaching a horse and never approach from behind. For your own safety, do not frighten the horses. Horses not in service will be resting; the resting area is off-limits.

**EVENT SAFETY** - All Events, Games, and Activities will be reviewed by the Games Coordinator and the Safety Coordinator on site. No event, game, or activity will be permitted to continue if an unsafe condition exists. Prior to resuming, it must be properly reviewed.

**OPEN FIRES** - Depending on conditions from the National Forestry Service, **it is possible that open fire bans may exist** during Pow Wow. This information will be communicated during the Outpost Senior Guide's Meeting on the first day of camp. If you plan to cook, make sure you plan for this contingency by bringing stoves, etc.

## CAMP RULES

- **Campfires** (if permitted) must never be left unattended. They must be extinguished before leaving the campsite. This includes tiki lamps.
- **No one** should be absent from the **services, morning formations, or other special events**. Do NOT allow your boys or leaders to stay in the campsite during these special times.
- No personal firearms of any kind are allowed on-site unless previously approved by the Security Officer. ***All conceal carry persons should be preapproved and registered by contacting Josh Guin, [nashvillehorseman@gmail.com](mailto:nashvillehorseman@gmail.com) or 615-818-7101.***
- No tobacco products, alcohol, or illicit drugs are permitted at camp. Individuals in possession of such items will be escorted from the campgrounds.
- Campsites and cabins must be clean before your departure. You will be required to have an inspector okay your area before you leave. **Rangers leave their area cleaner than they found it.** You are required to haul all your trash to the designated area. Please clear the campground no later than 1:00 on Saturday.
- Do not cut live trees.
- Do not enter any cultivated field of crops.
- Avoid and do not approach any snakes you might encounter.
- Recommended leader to boy ratio is 1 to 5.
- **No** sheath knives are allowed at camp **except** as part of an FCF outfit.
- Knives can be traded by commanders only in the FCF Village and only during Traders Row. If a commander buys or trades a knife for a boy, he **must** keep it put up and **not** let the boy have it until returning to his church. We recommend that it be given to his parents.
- You and your outpost must be present at the awards presentation to receive your awards and to receive your patches for your boys. If you must leave early, please make that known at check-in so provision can be made to mail the patches to your home church.
- Commanders, it is your responsibility to ensure your boys shower and keep their bodies clean during Pow Wow. Make sure that your boys shower!
- Once on site, you are expected to stay on the camp property. If you find it necessary to leave for a short period, you will need to sign out at the first aid station or with security.
- No gas-powered devices or generators will be permitted. We will have a quiet Honda generator for those that may have a medical need for a generator. Let us know on the medical form in the remarks section.

## COMPETITIONS

The **Competition Entry Form** must be submitted at check-in time upon arrival at camp. Judging will be based on workmanship, originality, difficulty to make, theme design, eye appeal, outpost identification, year, and district identification. Work is to be done by the boys in the outpost. See **Judging Form** for guidelines.

\* To enter the competitions, the "Competition Entry Form" must be submitted at check-in time upon arrival at camp.

### OUTPOST PARTICIPATION AWARD

This year the **BIG TROPHY** is the **Outpost Participation Award**. To win it, outposts will participate in as many events as possible. Each event around camp will earn them points towards the OPA Award. District staff will be able to add points when they see a boy doing something extra good. For example, a boy cleans up a mess he didn't make, a boy helps set-up, take-down, or run an event. These types of things do not guarantee extra points, but they are possible depending on what the staff member observes.

### BEST OUTPOST STANDARD (FIRST & SECOND PLACE TROPHIES)

See **Judging Criteria** for criteria, points, and targeted areas of interest.

### BEST GATEWAY (FIRST & SECOND PLACE TROPHIES)

See **Judging Criteria** for criteria, points, and targeted areas of interest.

### BEST CAMPSITE (FIRST & SECOND PLACE TROPHIES)

See **Campsite Judging Criteria** for criteria, points, and targeted areas of interest.

### SOCCER

- Five on five. There can only be one commander on each team. The team can be five boys or four boys and one commander. We can divide the competition into the different age groups – Discovery, Adventure, and Expedition – if there is enough interest.

### TUG OF WAR

- This will be 1200 pounds vs. 1200 pounds. The number of people on each team is irrelevant. It can be as many people as are needed to total but not exceed 1200 pounds.

### .22 RIFLE, SHOTGUN, BB GUN, AND ARCHERY

- We will recognize the 1st, 2nd, and 3rd place shooters for each event for each age group.

### TOP SHOT

- We will have an award for the Top Shot - the person with the best average score from 22 rifle, shotgun, BB gun, and archery combined.

### PAINTBALL – no trophies awarded . . . just bragging rights

- Paintball guns will be provided for all participants. You may bring your own gun or your own hopper (no automatic hoppers), but the pressure will be turned down on site.
- Do not bring your own paintballs. These will be provided.
- Mask/goggles will be provided, or you may bring your own. All other equipment you can bring - clothing, accessories, etc. You **MUST** bring a signed copy of the **Paintball Release Form**, signed by your parent or legal guardian. (Your commander is not authorized to sign your permission form.) Without this, we will not be permitted to let the boys play. Special arrangements cannot be made once on site for this requirement.

### WATERMELON EATING

- One team consisting only of 3 boys and 1 commander, or 4 boys will be invited to participate in the watermelon contest. Additional teams from each outpost may participate for \$10.00 per extra team/watermelon. Register for the watermelon contest at check-in to ensure we have enough watermelons.

## **CARDBOARD REGATTA**

- Best Design
- Racing

### **Official Rules and Specifications for the Cardboard Regatta**

**Restrictions: Cardboard is the only approved building material.**

**\*\*\*NO PLYWOOD ALLOWED\*\*\* \*\*\*NO PRE-WAXED CARDBOARD\*\*\***

**Cardboard Source:** Corrugated cardboard is available from Weyehaeuser in Elmire, NY or scrounge through furniture and appliance dealers recycling bins. Places like Lowes will have free cardboard sheets, large enough to build your boat from one sheet, in the shipping and receiving area if you call ahead and ask for them.

### **Safety Rules:**

The passenger area of the boat must not be permanently enclosed above the shoulders of the occupants. Each occupant must be visible while the boat is in the water.

Boats must be free of sharp edges or anything that could pose a danger.

All participants must wear a personal flotation device before entering the boat and while the boat is in the water.

If your boat sinks, you are disqualified from the race and should exit the water as soon as possible.

Participant may not menace another participant. Poor sportsmanship will result in disqualification. Sunken or discarded vessels must be disposed of by the outpost crew at the conclusion of the race.

Each vessel must carry a closed 1-gallon plastic jug with a 15' rope tether firmly attached to the vessel for use in locating and retrieving any sunken remains.

No loose items, especially items which may sink may be carried during competition.

Throwing water on another boat is reason for disqualification, unless said water comes by accident from the splash of the paddle/oar.

A legitimate de-watering device may be used to remove water from within a sinking vessel.

### **Boat Building Basics:**

Develop a concept related to theme:

Sketch your creative ideas on paper.

Calculate length, width, height, draft, balance; consider size and weight of crew.

Build a scale model.

Boats are limited to 40" wide and 96" long for a crew of two people.

The sides must be limited to 18" or a height that would allow rowing motion under the arm.

### **Construction Steps:**

Transfer model or concept to cardboard.

Mark lines.

Cut cardboard, bend cardboard.

Brace, glue, tape seal

Waterproof with materials listed in suggested supplies

**Suggested Supplies:**

Corrugated Cardboard – three layers for floor, two layers for walls

Acrylic latex caulk

Wood glue liquid nail adhesive or dap contact cement

Water seal, polyurethane

Paint, including latex house paint

Paper tape, masking tape, or duct tape – no more than one roll of duct tape per boat

**Tools needed:**

String line for straight edge, right angle or squaring tool

Carpet knife or exacto knife

Foam brush, paint brush or roller

Creasing tool (Scissors work well.)

Clamps (spring & quick)

Measuring tape

**Types of Paddles:** canoe type paddles (single blade) Consider whether you'll be rowing alone or with others.

**Testing:** Test prior to the event or take your chance on Regatta Day.

**Judging:** Trophies/ribbons will be awarded in the following categories:

**Fastest Boat** (first, second, and third place) –. Boats will be timed around a closed course. After three heats, the three boats with the fastest average times will race a fourth time head-to-head to determine the winner. Each boat will have two people in it for racing, but if desired, rowers/riders can be exchanged after each heat. In the event of a tie, additional match races may be ordered by the judges to establish the winner.

**Best Overall Design** – (first and second place) Prior to the racing, the judging staff will examine all vessels and select the vessel whose construction and appearance are deemed to be the most elegant, including special consideration for theme and presentation. One member of each crew will be allowed to "explain" their vessel's design, theme, and significance.

## **OUTPOST RACER**

- Best Design
- Racing

### **Official Rules and Specifications for Outpost Racer**

The Design category will have first, second, and third place trophies. The Racing category will have first, second, and third place trophies in each of three divisions: Discovery Rangers, Adventure Rangers, and Expedition Rangers.

If you want to enter just the racing event and compete for the racing trophies, your outpost will build the standard racer. Plans are shown on the next pages for those needing to build a racer this year.

If your outpost desires to compete in the design category and compete for the design awards, then your “vehicle” must be theme related and must be raceable.

Your outpost may enter both the Design and the Racing events with the same vehicle. Of course, it will have to be theme related. Each outpost may enter one vehicle. Bring cars on Monday before supper for inspection and judging. Please make sure you have the Outpost Number on the car.

### **Outpost Racer Racing**

Downhill Racers will check-in for safety pre-inspection on Monday before supper. The final inspection (if changes had to be made to the racer) will be the morning of the race. The Camp Safety Coordinator will make the final decision on all racing decisions.

1. Cars must meet specifications for width of wheelbase, length of wheelbase and type and size of wheels. See next page for specifications. The racer frame must be made of wood.
2. Drivers who crash into other racers will forfeit that race. The other racer/driver will automatically be declared the winner. This forfeiture decision is made by the judges at the time of the race and is a non-contestable decision.
3. A vehicle that is judged unsafe by the racing judges will not be allowed to race. This vehicle may be entered in the Design competition if it meets design specifications. This rule will not be “nit-picky” but will be used to disqualify obviously unsafe vehicles. Two or more judges must concur to disqualify a vehicle as unsafe.
4. One car may compete in all three divisions of the racing event: Discovery Rangers, Adventure Rangers, and Expedition Rangers.
5. Each car must have an approved bicycle or motorcycle style helmet for the inspection. Drivers must wear a helmet while racing.
6. Rope steering must be permanently attached to the car’s steering axle.
7. The driver must wear a seat belt that is firmly attached to the frame. No bungee cords or rope.
8. Wood blocks must be secured to front axle at 1/8” on either side of mainframe (E) to limit the turning radius and help prevent oversteering while racing. See Item B on the design sheet.
9. Wood panel must be secured to front axle support to keep boy’s feet off ground and can be used as a braking device. See Item D on the design sheet. Other braking devices are permissible.

### Outpost Racer Basic Design

These plans are provided to assist in the design and construction of your outpost racer. There are four (4) main requirements for qualification in the racing and the design events: 1) Length of Wheelbase, 2) Width of Wheelbase, 3) Size of Wheel, and 4) Rope Steering. The plans below are a guide. If you are building a new racer, please build it with the Pow Wow theme in mind. Have a great time with your racer.

### Required Dimensions

1. Length of Wheelbase – from center of front axle to center of rear axle = no less than 42" and no greater than 50".
2. Width of Wheelbase – from center of left wheel to center of right wheel = no less than 27" and no greater than 32".
3. Wheels - No ball bearings and/or sleeved hubs. Plastic or neoprene hubs only. No less than 7" in diameter & no more than 9" in diameter. Lubricant on hubs & axles OK.

### Basic Outpost Racer

A = 2" x 4" x 27" wooden axle supports.

B = Wood blocks secured to front axle at 1/8" on either side of mainframe to limit steering

C = 1/2" x 5", bolt with necessary washers & nuts for steering axle.

D = 15" x 23" x 1/8" wood panel.

E = 2" x 6" x 52" wood main frame.

F = 12" x 18" x 3/4" wood seat back

G = 12" x 18" x 3/4" wood seat

H = 2" x 6" x 12" back support posts (2 needed)

I = 1/8" back support panels, 7 1/2" at top, 15" vertical, and 11" across bottom.

J = U-bolts to secure axle e (min. 2 per axle)

K = Wheels, see required dimensions

L = 1/2" steel axle or equal

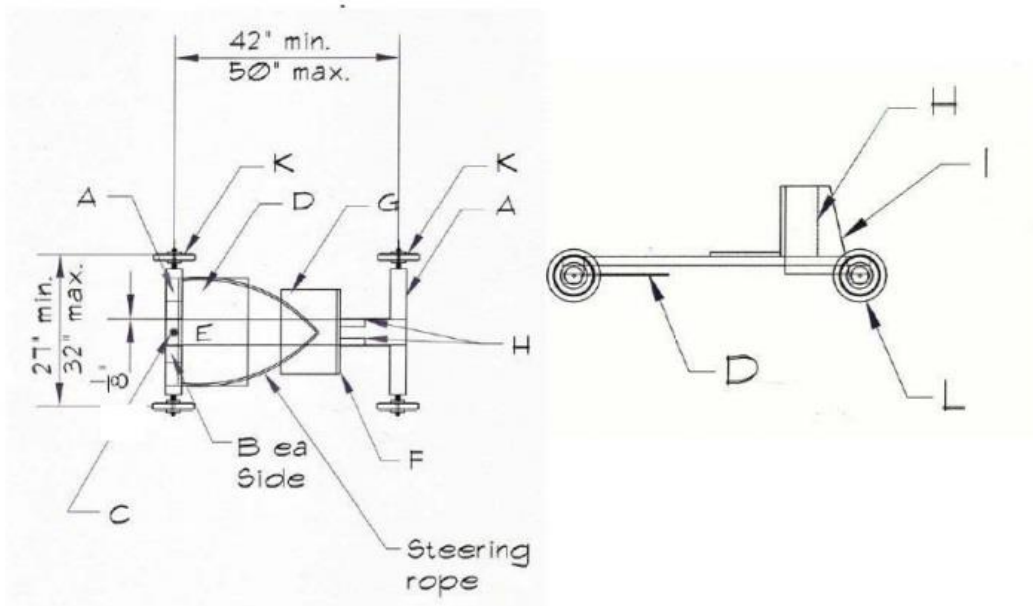

## **JUNIOR BIBLE QUIZ FACT-PAK**

Our Tennessee District Bible Quiz Director will visit Pow Wow this year to offer the boys (and men) an opportunity to see what Bible Quiz competitions are about. Following is a sample of questions and answers if the boys want to study some of them ahead of time.

### 10-point questions

1. What is the Bible? The Bible is the inspired Word of God and is His revelation to all people of himself and His plan of salvation.
  2. How many books are there in the Bible? 66
  3. What are the two divisions of the Bible? Old Testament and New Testament
  4. What does "testament" mean? Covenant [contract or agreement]
  5. How many books are in the Old Testament? 39
  6. In what language was most of the Old Testament written? Hebrew
  7. How many books are in the New Testament? 27
86. (QQ– Quotation Questions must be answered exactly, the address may be said before or after the scripture)  
Which is the first of the Ten Commandments? Exodus 20:3 "You must not have any other god but me."
183. QQ With what words did John the Baptist introduce Jesus? John 1:29  
"Look! The Lamb of God who takes away the sin of the world!"
185. Which of the disciples was a tax collector? Matthew
186. After Andrew met Jesus, what did he tell his brother Simon Peter? We have found the Messiah.
192. Who were the first four apostles Jesus called to follow Him? Peter, Andrew, James, John
200. Which three of the disciples were Jesus' closest friends? Peter, James, John
254. In Ephesians, what command does Paul give to the children? Children, obey your parents.
270. Why do we love God? We love Him because He first loved us.
275. What is sin? Sin is refusing to do God's will as revealed by His Word and His Spirit.
276. What is grace? Grace means that God offers us His love and forgiveness as a gift and not because we have earned it or deserve it.



282. What is a disciple? A disciple is a learner [follower] of Jesus.

284. What is praise? Praise is expressing our love to God for all He is and all He has done.

285. What is worship? Worship is exalting and adoring God for who He is.

20-point questions

289. How did God give us the Bible? The Holy Spirit inspired holy men, giving them both the truth and the words to write.

294. QQ Why is it important to memorize Bible verses? Psalm 119:11 I have hidden your word in my heart that I might not sin against you.

295. Does the Bible claim to be inspired? The words, "and God said," or their equivalent, are found over 2,500 times in the Bible.

314. QQ Has Jesus always been God? 1:1 In the beginning the Word already existed. The Word was with God, and the Word was God.

315. What is Jesus' title of divinity? Son of God

316. What is Jesus' title of humanity? Son of Man

317. QQ Quote the verse that says Jesus is always the same. Hebrews 13:8 Jesus Christ is the same yesterday, today and forever.

319. Over how many different Old Testament prophecies were fulfilled by the life and death of Jesus? [Over] 300

335. In the Parable of the Good Shepherd, what did Jesus say the Good Shepherd would do for the sheep? Sacrifice his life

469. What happens to a Christian's soul and spirit at death? The Christian's soul and spirit go immediately to be with the Lord.

30-point questions

490. What five books of the Bible are called the "Pentateuch?" Genesis, Exodus, Leviticus, Numbers, Deuteronomy

495. What are the five books of New Testament history? Matthew, Mark, Luke, John, Acts

496. What are the thirteen epistles written by Paul? Romans, 1 & 2 Corinthians, Galatians, Ephesians, Philippians, Colossians, 1 & 2 Thessalonians, 1 & 2 Timothy, Titus, Philemon

508. What does the Bible tell us about the life of Jesus between the time He was 12 and 30? He obeyed His parents, grew mentally and physically, and gained favor with both God and people.

549. What was Jesus' last command to His apostles before His ascension? Jesus told them not to leave Jerusalem until they had received the gift of the Holy Spirit [baptism in the Holy Spirit].

559. What does it mean to be a good steward? Being a good steward is recognizing that all we have and all we are has been given to us by God and is to be used wisely in furthering the work of God.

## LINKS FOR FORMS

As much as possible, we encourage online registration. Take advantage of the “Save and Resume” feature of the online forms. If your form is only partially complete, save your progress to receive an emailed link that will allow you to pick up where you left off. This link can be shared with pastors and parents to help in getting the necessary signatures.

If necessary, however, a printable version of the registration forms may be used to collect needed information and signatures. There is a separate download button on the website for the printable version of the forms.

### **OUTPOST REGISTRATION FORM**

[https://www.cognitofrms.com/TNRoyalRangers/\\_2024TNPOWWOWREGISTRATIONFORMOUTPOST](https://www.cognitofrms.com/TNRoyalRangers/_2024TNPOWWOWREGISTRATIONFORMOUTPOST)

### **BOYS REGISTRATION FORM**

[https://www.cognitofrms.com/TNRoyalRangers/\\_2024TNPOWWOWREGISTRATIONFORMBOYS](https://www.cognitofrms.com/TNRoyalRangers/_2024TNPOWWOWREGISTRATIONFORMBOYS)

### **ADULT REGISTRATION FORM**

[https://www.cognitofrms.com/TNRoyalRangers/\\_2024TNPOWWOWREGISTRATIONFORMADULTS](https://www.cognitofrms.com/TNRoyalRangers/_2024TNPOWWOWREGISTRATIONFORMADULTS)

### **JLDA REGISTRATION FORM**

[https://www.cognitofrms.com/TNRoyalRangers/\\_2024TNJLDAREGISTRATIONFORMBOYS](https://www.cognitofrms.com/TNRoyalRangers/_2024TNJLDAREGISTRATIONFORMBOYS)

### **RANGER RUN AND NATURE WALK 5K**

[https://www.cognitofrms.com/TNRoyalRangers/\\_2024TNPOWWOWRANGERRUNNATUREWALK5KForMISSIONS](https://www.cognitofrms.com/TNRoyalRangers/_2024TNPOWWOWRANGERRUNNATUREWALK5KForMISSIONS)

### **PAINTBALL LIABILITY WAIVER FORM**

[https://www.cognitofrms.com/TNRoyalRangers/\\_2024TNPOWWOWPaintballLiabilityWaiver](https://www.cognitofrms.com/TNRoyalRangers/_2024TNPOWWOWPaintballLiabilityWaiver)

### **COMPETITION ENTRY FORM**

[https://www.cognitofrms.com/TNRoyalRangers/\\_2024TNPOWWOWCOMPETITIONSEENTRYFORM](https://www.cognitofrms.com/TNRoyalRangers/_2024TNPOWWOWCOMPETITIONSEENTRYFORM)

### **POWWOW PATHFINDER APPLICATION FORM**

[https://www.cognitofrms.com/TNRoyalRangers/\\_2024TNPOWWOWPATHFINDERAPPLICATION](https://www.cognitofrms.com/TNRoyalRangers/_2024TNPOWWOWPATHFINDERAPPLICATION)

## PAYMENT INFORMATION

Pay with credit card or PayPal at <https://tnrangers.org/tn-pow-wow/>

or

Checks payable to Friends of Rangers may be mailed to:  
Steve Iles, 1202 Abernathy Way, Mt. Juliet, TN 37122